

**INSTALLER: THESE INSTRUCTIONS CONTAIN IMPORTANT SAFETY INFORMATION AND MUST BE FORWARDED TO THE BOAT OWNER.**

THIS IS A REPLACEMENT PART FOR THE BALL POST AND CLAMP BLOCK ASSEMBLY IN STEERING CONNECTION KITS SA27255, SA27256, AND SA27332, MANUFACTURED BY TELEFLEX, INCORPORATED, U.S.A.

### WARNING

READ THESE INSTRUCTIONS THOROUGHLY BEFORE BEGINNING INSTALLATION. FAILURE TO FOLLOW THESE INSTRUCTIONS, OR INCORRECT ASSEMBLY COULD RESULT IN STEERING FAILURE WITH SUBSEQUENT PERSONAL INJURY AND PROPERTY DAMAGE. IN ORDER TO OBTAIN THE BEST STEERING PERFORMANCE, THE OUTBOARD MOTOR OR OUTDRIVE MUST BE INSTALLED AND LUBRICATED AND THE TRIM TAB ADJUSTED IN ACCORDANCE WITH THE MOTOR MANUFACTURER AND THE BOAT MANUFACTURER'S SPECIFICATIONS. CHECK THE CONTENTS OF THIS KIT AGAINST THE PARTS LIST ON THIS INSTRUCTION SHEET. USE PARTS SUPPLIED ONLY AS INSTRUCTED ON THIS SHEET. DO NOT SUBSTITUTE PARTS OR COMPONENTS FROM OTHER STEERING MANUFACTURERS. THEY MAY CAUSE A SAFETY HAZARD FOR WHICH TELEFLEX, USA CANNOT ACCEPT RESPONSIBILITY.

### PREPARATION FOR INSTALLATION

NOTE: DO NOT DISCONNECT CABLE FROM MOTOR OR LOOSEN CABLE COUPLER NUT FROM SUPPORT TUBE.

1. Mark location of old Clamp Block on Support Tube, then remove hardware attaching Clamp Block.
2. Carefully note orientation of old Ball Post (pointing up or down), then remove hardware attaching Ball Post to transom.

### INSTALLATION INSTRUCTIONS

1. Attach new Ball Post (item 1) to transom with the post pointing in the same direction (up or down) as the original one. NOTE: DO NOT MOUNT SIDWAYS. (See Figure 1). First, place Flatwasher (item 2) on Hex Bolt (item 3), then insert Bolt thru Ball Post base and hole in transom. Add Flatwasher (item 2) and thread on Lock Nut (item 4). Install the other three sets of hardware in same manner, and torque to 75 inch/pounds. DO NOT EXCEED 100 INCH/POUNDS.

2. Place Clamp Block Bracket (item 5) around the Support Tube in the location previously marked, and over the ball on the end of the Ball Post. (See Figure 2).

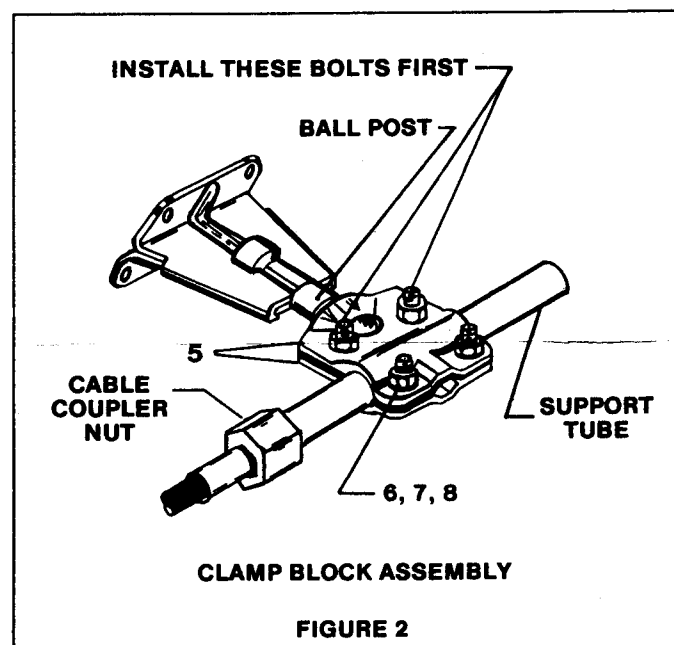
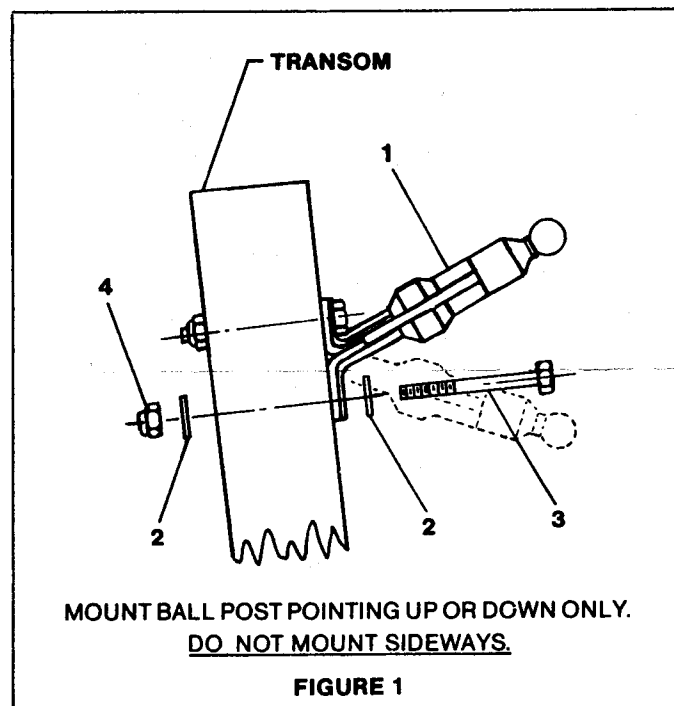

Insert two Hex Bolts (item 6) thru rear holes (next to Ball Post) as shown. Add one Flatwasher (item 7) to each Bolt, and thread on Lock Nuts (item 8). Torque hardware to 100 inch/pounds minimum. DO NOT EXCEED 130 INCH/POUNDS.

Install hardware (items 6, 7, 8) in the front holes and torque to 100 inch/pounds minimum. DO NOT EXCEED 130 INCH POUNDS.

**WARNING**

**HARDWARE MUST BE INSTALLED AND TIGHTENED IN THIS SEQUENCE. FAILURE TO DO SO COULD ALLOW CLAMP BLOCK TO PULL OFF BALL POST, RESULTING IN LOSS OF STEERING.**

**STEERING TRAVEL CHECK**

With the steering wheel, operate the steering system fully in both directions to assure equal travel of motor. Should further adjustment be required, loosen Clamp Block hardware and slide Support Tube in the desired direction. Re-torque hardware to specifications noted above.

**FINAL MECHANICAL CHECKOUT**

1. Move the motor thru the normal operating positions (side to side and tilting up and down) to assure that no interference or restriction of movement exists.
2. Check Coupler Nut attaching Steering Cable to Support Tube and all attaching hardware for security and re-torque if necessary.
3. Using the steering wheel, check for proper action of steering controls. Rotating the wheel clockwise (to the right) should cause the boat to turn to the right (starboard).

The installation is now complete.

**WARNING**

**THE BOAT SHOULD BE OPERATED WITH CARE UNTIL THE STEERING SYSTEM HAS BEEN THOROUGHLY CHECKED OUT UNDER NORMAL OPERATING CONDITIONS TO INSURE THAT THE INSTALLATION IS CORRECT AND FUNCTIONING PROPERLY.**

**MAINTENANCE NOTES**

1. AFTER A FEW HOURS OF OPERATION FOLLOWING INSTALLATION OF THIS KIT AND PERIODICALLY THEREAFTER, RE-TORQUE ALL FASTENERS AND CHECK THE STEERING SYSTEM FOR SECURITY AND INTEGRITY.

**WARNING**

**LOOSENING OR SEPARATION OF ONE OR MORE FASTENERS MAY CAUSE FAILURE OF THE STEERING SYSTEM, RESULTING IN PROPERTY DAMAGE AND PERSONAL INJURY.**

2. INSPECT PERIODICALLY FOR CORROSION. ALL METAL PARTS MEET OR EXCEED APPLICABLE SPECIFICATIONS FOR CORROSION RESISTANCE. HOWEVER, WITH EXTENDED OPERATION UNDER EXTREME CONDITIONS, CORROSION MAY OCCUR AND AFFECTED PARTS SHOULD BE REPLACED.

**PARTS LIST**

Item	Description	Quan.
1	Ball Post Assembly	1
2	Flat Washer 1/4" ID	8
3	Hex Bolt 1/4-28 x 2-1/2"	4
4	Lock Nut 1/4-28	4
5	Clamp Block Bracket	2
6	Hex Bolt 5/16-18 x 3/4"	4
7	Flat Washer 5/16" ID	4
8	Hex Nut 5/16-18	4